

**DESIGN AND IMPLEMENTATION OF A VIRTUAL E-LEARNING SYSTEM IN
NNAMDI AZIKIWE UNIVERSITY, AWKA, ANAMBRA STATE**

Ifeyinwa Faith Ogbodo,

**Industrial & Production Engineering, Nnamdi Azikiwe University, Awka, Anambra
State. Email: if.ogbodo@unizik.edu.ng**

Abstract

The demand to acquire knowledge or to learn has rise, thus, the present technology had gone a long way to provided means to learn, irrespective of the distance or the location of the e-learner and source of information. This is achieved through electronic sharing of information and virtual classroom. However, virtual classroom and text based e-learning is a system design to help student gain access and acquire knowledge in any university of their choice. This method of learning will enhance face – to - face instruction or campus, use of computer in classrooms and elicitation of information with the World Wide Web (www) enhanced distance education (on or off campus). Individual and group learning with both print and computer based materials.

With all these, virtual classroom and test based e-learning knowledge is moving towards every students and staff of Nnamdi Azikiwe University, Awka (for instance) being an e-learner at least for part of their study, this could be through learning materials e-mails contacting tutors or submitting assignment, the use of website for research or any one of the myriad e- learning application.

Keywords: Virtual e-learning, Computer, World Wide Web (www), Internet

Introduction

Virtual e-learning is a system designed to help students gain access and acquire knowledge in any university of their choice. It can include: Enhance face –to- face instruction (on campus, in class use of computer and the World Wide Web (www), enhanced distance education (on or off campus) individuals and group learning with both print and computer-based materials instruction entirely on-line (individual and group learning) because of this mix virtual classroom and text based e- learning knowledge is moving towards every student being an e- learner at last for part of their study, whether through learning materials, e-mail for contacting teachers/ tutors or any one of their myriad other e-learning applications.

Online learning results to learning and other supportive resources that are available through a computer and it includes computer based training, computer based instruction and technology. The e-learning system use text messages to deliver information and data. Student or e-learners will be in their computer receiving lectures as if they are in classroom. This has gone a long way helping e-learners to acquire degree in the institution they have never seen.

Internet as global connection of computers sited around the world forming huge network for information to be shared and disseminated by many millions of people has done so well in information technology and in education so to speak. Virtual classroom and text-based e-learning cannot be an exception. Often time's students experience a lot of difficult in the quest for basic

knowledge from higher institution of their choice, not for the fact that the person doesn't have resources to acquire them but the risk in traveling from the said institution wherever the person might be pose problems. In order to reduce these risks, satellite computer were established but did not solve the problem of traveling out from one's location to the said location in quest for knowledge.

In this regard, Nnamdi Azikiwe University (NAU), compete with other institutions, this sometimes reduces the number of students enrollment in the school to the above listed problems the system "virtual classroom and text based e- learning was designed with this University of Benin will have thousands of student in which she doesn't provide any a accommodation or any structure for and still gain much grounds economically and student all over the world suffer less in having any of NAU certificate.

This system is designed such that before anybody can participate he/she must register. Students have free registration form but lecturers must provide their staff number that tally with their surnames before they have access to registration form. One month is giving to student to pay his/her school fees after registration to remove his/her name from the database.

This will go along way increasing student's enrollment in the institution. The system has very security conscious software that resides in the ever helping except those supposed. Having seen and observed. Having seen and observed this benefit to students in an unprecedented scale.

Indeed, this sounds interesting to my academic pursuit in. Perhaps this calls for implementation.

Due to the problems students find and experiences, it has never been easy for students to acquire basic and necessary education in any institution one wishes irrespective of the fact that the resources are there. This poses a lot of problems sometimes they will embrace not going to school at all. It is very impossible for a student in America or any other country coming to NAU everyday for lectures more so, it will be impossible for NAU staff going to America or any other country where the students might be located everyday to deliver lectures.

Sometimes if number of students increase reduction in student" admission will be affected in order to provided adequate structures where they can have their lectures. The above views are what gave birth to the research work in order to find solution to them.

The purpose of the study is to find possible solution to students whom because of distance from institute, are unable to acquire knowledge that they need. Again, to provide students easier way to acquire any of the NAU certificates without been in the institute or with less difficulty. Notwithstanding the fact that other institutes who offer the same courses as NAU exist, this will go far reducing her competition with them. Since the system is virtual, that is, there will be no physical contact between students, their instructors and NAU, the problem structure is solved.

Literature Review

Within the United States and Canada, the phrase "e-learning" is often treated by users as a synonym for "online learning" – a more recent term, the very construction of which implies a fundamental relationship between e-learning practices and Web-based technologies like the Internet (1). However, as many educational scholars have pointed out, the earliest examples of e-learning practice significantly pre-date the invention of the Web, beginning with the invention of email in the early 1970s and continuing with the establishment of innovative "virtual schools" in the early 1990. Consequently, most educational scholars have rejected the synonymous use of the terms "e-learning" and "online learning," and promoted instead the development of more inclusive e-learning definitions, such as "the use of new information and communication technologies in education" (2).

This movement to come to some practical consensus about scope of e-learning suggests a significant step in the collocation, and hence development, of future e-learning research. In the late 1990s and early 2000s, interest in e-learning, both scholarly and commercial, increased substantially, particularly in the United States, Canada, and Australia. Studies of American students in virtual programs at both the elementary and secondary level led researchers to tout e-learning's many benefits, including but not limited to its flexibility in geography and scheduling, its ability to address various learning styles, and its overall expansion of educational access to people in remote communities (3). While some of these studies have since been criticized for not being based on "robust [enough] research", the general impression of, and evidence for e-learning as Paradigmatic shift in the field of education remains basically intact. Indeed, according to a 2009 report on the state of online-based e-learning in U.S higher education Seaman, 2010, over 4.6 million American students took at least one online course during the fall 2008 academic term – a 17 percent increase over the number of students reported in fall 2008. With student participation in e-learning increasing in this way, a number of educational researchers – particularly those interested in post-secondary education – have attempted to explore variations in e-learning programs' curriculum designs, delivery modes, social communities, and instructional training methods. Furthermore, over the past five years, such explorations have gradually but distinctly shifted the geo-cultural scope of e-learning discussions beyond the boundaries of the North American and Australian higher education systems, and into the higher-education options of students in regions such as South Asia (4). As a result of this widening and deepening of twenty-first century e-learning research, more results have also emerged in critique of the so-called "benefits" of certain e-learning models and components. For example, several authors have published recent papers highlighting the hidden costs of bringing e-learning to new countries' higher education systems, from the cost of putting in place a widely accessible national telecommunications infrastructure to those costs associated with the establishment of national accreditation agencies for e-learning programs and institutions (2). Such discussions of cost are particularly significant to researchers investigating the potential and/or presence of e-learning programs in the most economically-challenged developing countries, and will likely play an important role in bringing together researchers interested in e-learning pedagogy with those who are more broadly interested in ICTs and global socio economics. use of technology as classroom aids, although over time, there has been a gradual increase in fully online learning.

The best examples follow a formative Assessment structure and are called "Online Formative Assessment". This involves making an initial formative Assessment by sifting out the incorrect answers. The author/teacher will then explain what the pupil should have done with each question. It will then give the pupil at least one practice at each slight variation of sifted out questions. This is the formative learning stage. In LAMS V2, e learning has been replacing the traditional settings Learning design is the type of activity enabled by software that supports sequences of activities that can be both adaptive and collaborative. The IMS Learning design specification is intended as a standard format for learning designs and IMS LD Level A is supported due to its cost effectiveness.

Methodology

In the analysis of the existing system, the information gathered were analyzed and restricted in a more relevant and useful data. Data analysis that was gotten was based on the identification of the

basic needs and also the structure of project. The data gatherer shows that they are analyze restructured in a way that the subsystem were system achieve efficiently. Learning facilities were provided in this e-learning system which helps greatly in learning package .There are also facilities for testing of knowledge

After achieving software requirement, the next step was to source for information relative to the subject. Information gathering can be gotten through different sources.

1. Checking of result and calculating of great point together with credit load.
2. Testing the ability of students.
3. Knowing the reasons and importance of e-learning.
4. Specifically in computer.
5. Opportunity of reading e-books with other relevant articles.
6. Personal observation.

The objective of the system is to develop a good E-Learning system that will

help in teaching and acquiring knowledge in technology to the students.

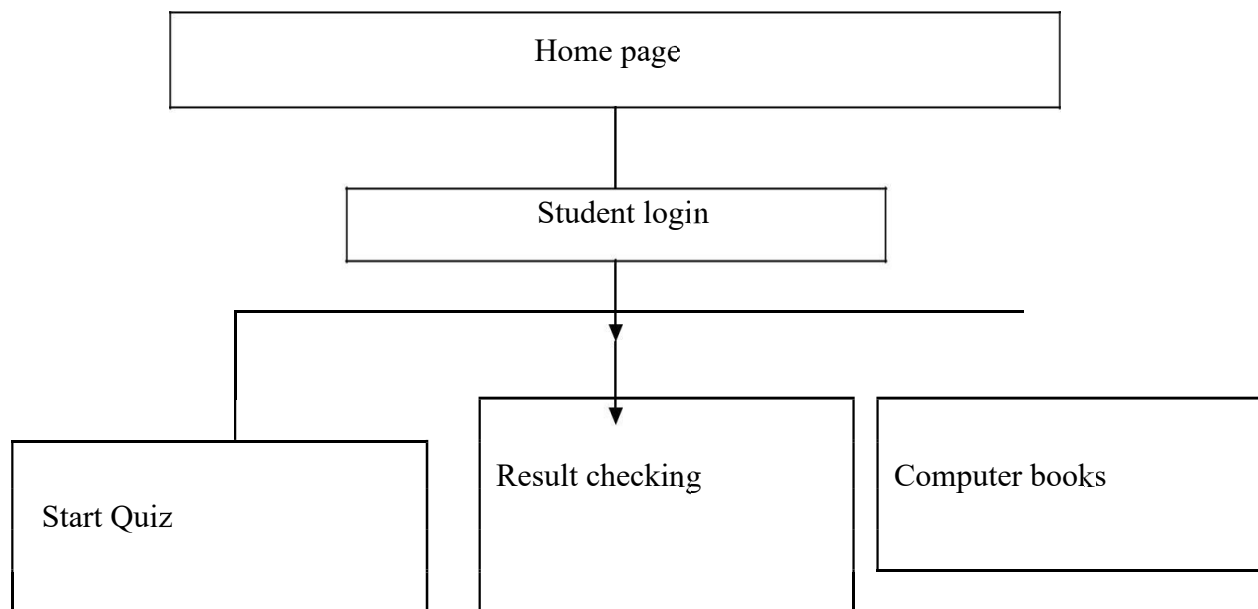

Fig 1: Information flow chart.

The student login forum is the input of the new system, the course registration, and the result checking and computer science courses these types of forums are gotten through the case study (NAU Computer Science). This is the process whereby you check for the correct answer and if you are unable to supply the answer, the software will then provide the correct answer for you. E-learning is the major part of the output analysis. E-Learning plays a major role in education because without E-learning it will be very hard for people to understand and learn fast. Qualified teachers are very scarce.

The organization and individuals benefit a lot from e-learning because it provides student with the opportunity to learn fast and have a good knowledge with e-learning one can have access to the internet to be more acquainted globally which makes learning more obtainable, affordable.

Design And Implementation Of The New System

The new system is design to work with the standard software development procedure .It is software structural that designed to meet up with student’s requirements and also has a structure that can detect every activity that takes place in the system. This e-learning is placed in VB 6.0 codes access the performance of students.

The output from the system is in the VB 6.0 Potable Document File (pdf) format page and it is open for everybody that wants to have access to it and can also be printed out any time.

File Design

SQL was used in the design .There are four tables used in the design the student login, the admin login, the question structure, and forum structure

Field	Field	Collatio
I -	Int(11)	
Usenam	Varche	Ut-generæ
Passwor	Varche	Ut-generæ

Fig3 Adminlogi

Field Name	Field Type	Collation
Id-	Int-(50)	
Fig 4.4 Student login		
Username	Varcher(50)	Utf-general-ci
Password	Varcher(30)	Utf-general-ci

Fig 2: Student Logging Database Structure

Field Name	Field Type	Collation
Id-	Int(11)	
Question	Varcher(60)	Utf-general-ci
Option 1	Varcher(60)	Utf-general-ci
Option 2	Varcher(60)	Utf-general-ci
Option 3	Varcher(60)	Utf-general-ci
Option 4	Varcheer(60)	Utf-general-ci

Fig 4: Question Structure

Field name	Field type	Collation
Id-	Int(50)	Utf-general-ci
Name	Varcher	Utf-general-ci
Question	Varcher	Utf-general-ci

Fig 5: Procedure chart

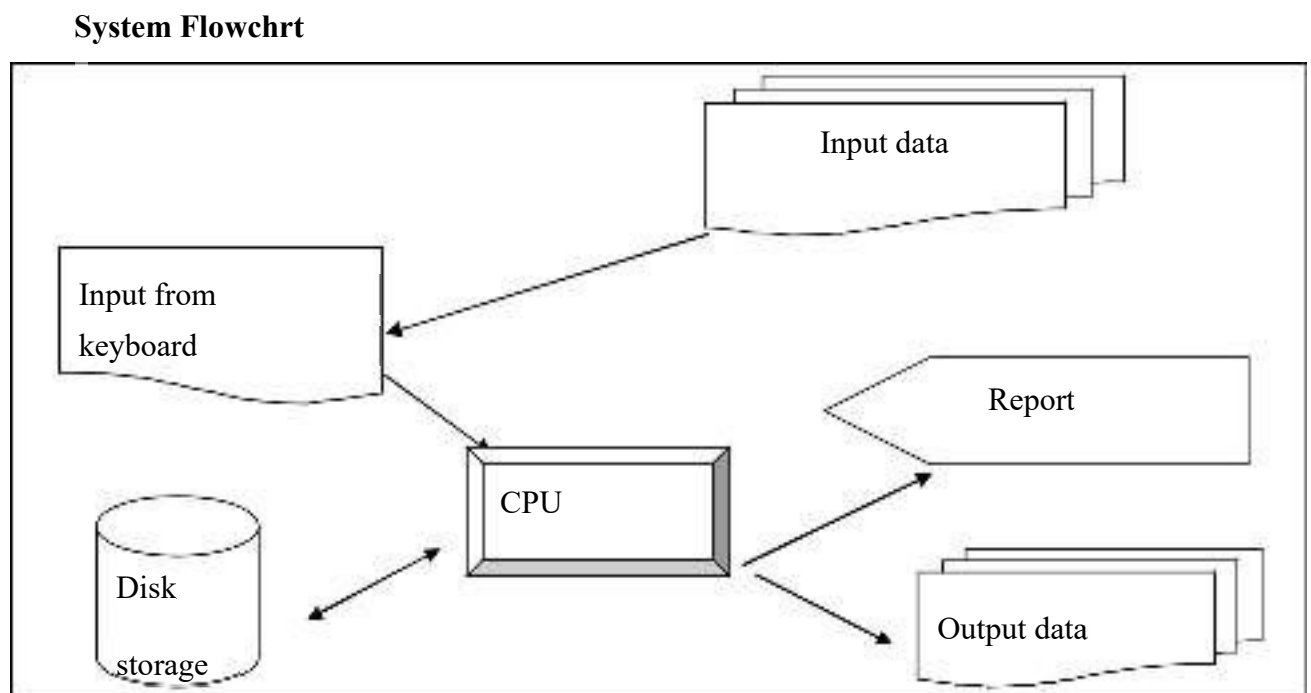

Fig 6: System Flowchart

System Requirements

The new system was develop using the following software which can make it to function effectively:

1. Intel core 13 computer system

2. 252 KB RAM
3. At least 40 GB hard disk
4. Enhanced keyboard
5. Color monitor
6. Uninterrupted power supply

Software requirements

The software was developed using the following:

1. Visual Basic 6.0
2. Window XP
3. Graphical application

Operational Requirement

Visual Basic application is needed so that the new system can function effectively.

Personal Requirement

A computer system that has visual basic installed in it.

Program Flow Chart

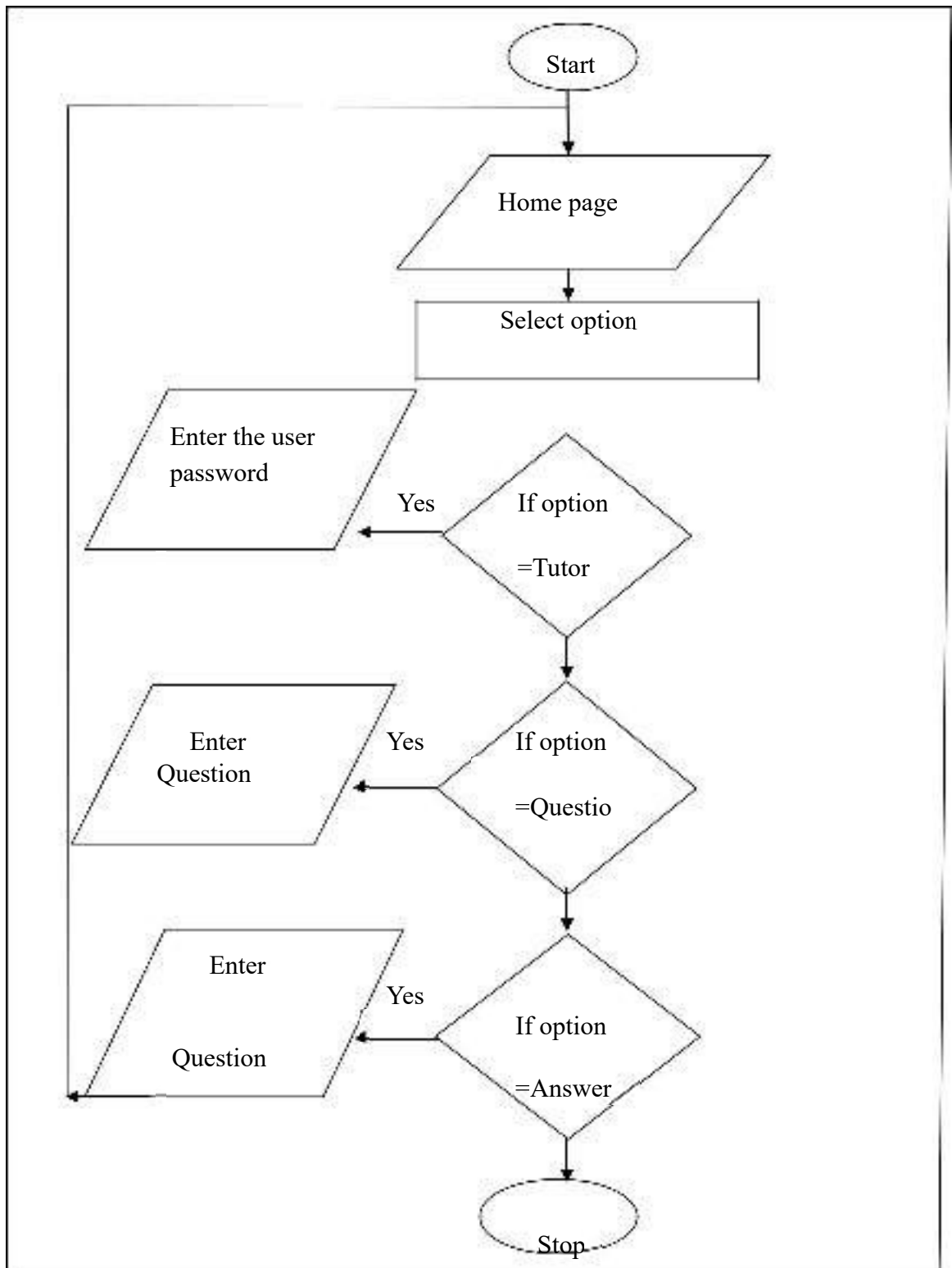

Fig 7: Program flow Chart

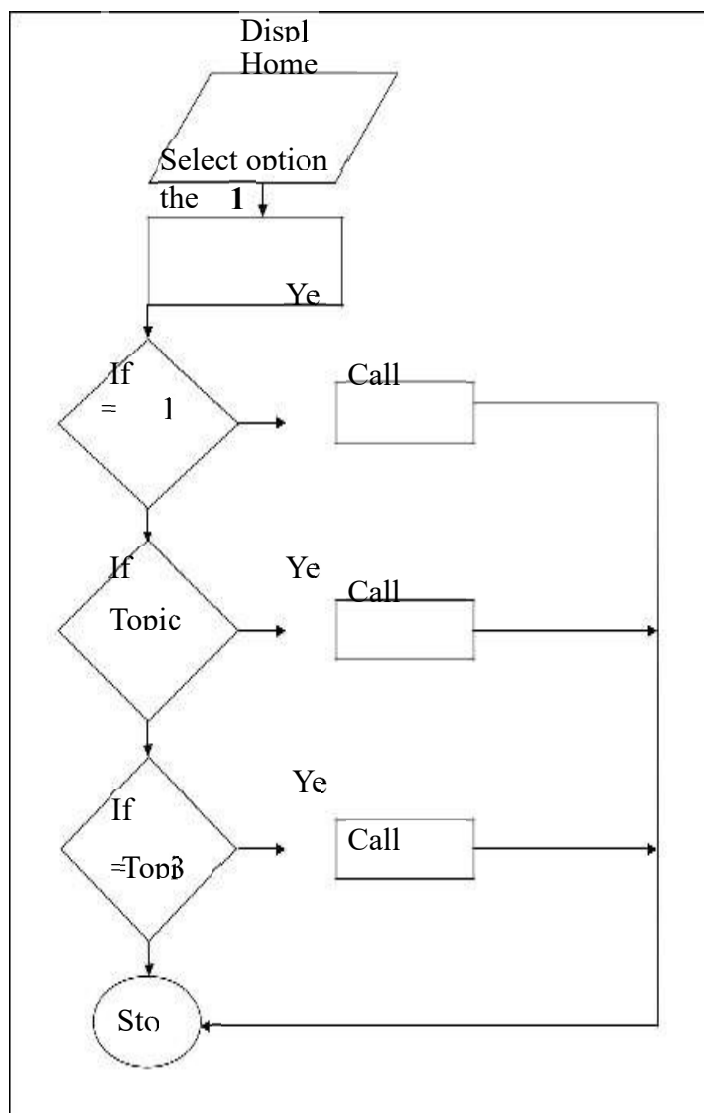

Fig 8: Program Flowchart

Conclusion and Recommendation

This research achieved the following:

1. Design and development of a computerized tutor.
2. Checking of results, was also design to help students check their results and also know their CGPA. You can as well test student's ability by answering the quiz question.
3. Computer science courses were also included to enable students to read courses and E-books.
4. The need of Visual basic is to design an application.

E-learning system as developed in this project will assist the user to test the knowledge of people around and means of accessing the understanding increases. With the advent of information in our developing and developed world, learning facilities are now on the increase. E-learning has added a lot of advantages to the training institutes as it teaches student and test their knowledge and add a lot of advantages to education standard as it reduces examination malpractice in our country. E-learning should be use as part of teaching standard in education to enable the student to acquire more knowledge.

REFERENCES

- Aleksandra ,Aristovnik. (2012). *The Impact of ICT on Educational performance and its Efficiency in Selected EU & OECD countries.*
- Bloom, B., Jossey B., & John W. (2013). *Taxonomy of Educational Objectives.* Bates, A. & Poole, G. *Effective Teaching with Technology in Higher Education.* San Francisco:
- Courts, B. & Tucker, J. (2012). Using technology to Create a dynamic classroom esperience. *Journal of College Teaching & Learning (TLC).*
- Dalsgaard, Christian. (2013). *Social Software Learning.* Beyond learning Management Systems . *Eurodl .org* . University of Aarhus.