

# Analysis of Solar-Powered Refrigeration Using Peltier Modules

Manoj Kumar<sup>#1</sup>, Ayush Raghav<sup>#2</sup>, Affan Alam<sup>#3</sup>, Ankit Kumar<sup>#4</sup>

<sup>#1</sup>Associate Professor, Department of Mechanical Engineering, IIMT College of Engineering, Greater Noida, India

<sup>#2</sup>Student, Department of Mechanical Engineering, IIMT College of Engineering, Greater Noida, India

<sup>#3</sup>Student, Department of Mechanical Engineering, IIMT College of Engineering, Greater Noida, India

<sup>#4</sup>Student, Department of Mechanical Engineering, IIMT College of Engineering, Greater Noida, India

[manojaarav07@gmail.com](mailto:manojaarav07@gmail.com), [ayushraghav445@gmail.com](mailto:ayushraghav445@gmail.com)

**Abstract**— There is a wide range of flexibility in using solar energy. An experimental evaluation of a solar-powered refrigerator with two Peltier modules for its cooling mechanism was carried out in this study. The study was conducted at IIMT college of Engineering in the climate of Noida. The system ran on solar power during the day and an additional battery at night to maintain the lower temperatures. The system's temperature dropped from 37.9°C to 16.9°C after 22 minutes and 6 seconds, enabling it to operate for 3.18 hours using an 84W battery pack.

**Keywords**— solar energy; solar powered refrigerator; compressor less; peltier module; thermoelectric cooling

## I. INTRODUCTION (Heading 1)

The production of electricity acts as a fundamental catalyst for a country's economic development. In recent decades, there has been a growing emphasis among researchers on renewable energy sources, moving away from non-renewable alternatives due to increasing pollution, population expansion, and the limited availability of non-renewable resources. In the late 18th century, the generation of electricity from non-renewable sources like coal began, which was soon followed by a heightened interest in alternatives such as nuclear power. Nevertheless, nuclear energy presents considerable dangers to nearby communities because of its radioactive characteristics, as demonstrated by the Chernobyl disaster in Kyiv, Ukraine. At present, researchers are mainly investigating solar energy systems, which provide a multitude of advantages, including being cost-effective, environmentally sustainable, and an unlimited energy source. As a result, solar energy is now applied in various fields, including heating and cooling through Flat Plate Collectors (FPC), electricity generation using Photovoltaic (PV) modules, solar distillation, and refrigeration, as depicted in Fig. 1.

Various researchers have studied solar energy and the use of Peltier modules in refrigeration, as detailed in the subsequent literature review.

## II. SOLAR POWERED COOLING AND HEATING

A solar-powered cooling and heating system is an energy-efficient and environmentally friendly solution that utilizes solar energy to maintain desired temperature conditions. This system converts sunlight into electrical energy using photovoltaic panels, which is then used to operate cooling and heating devices. In this project, thermoelectric modules based on the Peltier Effect are employed to achieve both cooling and

heating by reversing the direction of current flow. The system consists of a solar panel, charge controller, battery, Peltier modules, and cooling fans for heat dissipation. During operation, one side of the Peltier module becomes cold while the other becomes hot, enabling efficient temperature control within a confined space. Such systems are particularly useful in remote areas where conventional power sources are unavailable, and they offer advantages such as low maintenance, compact size, and eco-friendly operation. However, the overall efficiency is limited compared to traditional refrigeration systems, and performance depends on solar availability and proper thermal management.

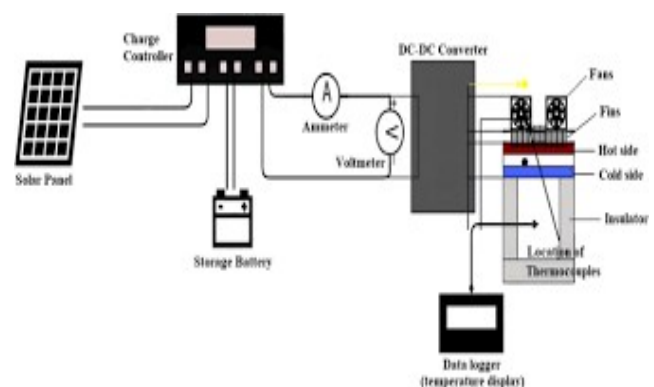

Fig.1 Block Diagram for Solar Powered Refrigeration

Conducted a theoretical examination of various working pairs, focusing on minimum and maximum working temperatures, cooling capacity, and coefficient of performance (COP) for solar-powered cooling systems.

Carried out an experimental study on a solar-based compressor-less refrigerator, employing a Peltier module for

cooling. The cooling side of the module reached a temperature of 10.6°C, while the hot side attained 65°C.

Performed an experimental investigation on a solar-powered refrigeration system designed for the climatic conditions of Egypt, with the COP of the system varying between 0.47 and 0.52.

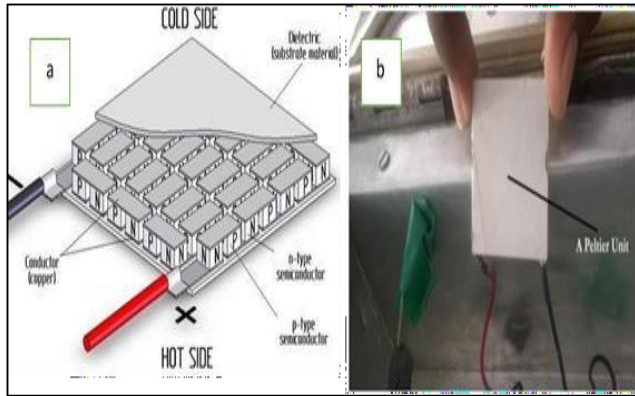

Fig.2 (a) Systematic Diagram of Peltier Effect (b) Peltier Module (TIC 12073)

Performed a simulation study that examined two scenarios:

(1) changes in working saturation temperature and (2) a constant working saturation temperature. In scenario 2, the performance metrics of refrigeration systems improve with higher solar intensity but decrease during the evening. In contrast, scenario 1 shows that performance metrics such as cooling capacity and power consumption diminish, suggesting that the system is more sensitive in this case.

performed a theoretical analysis and determined that liquid desiccant systems and absorption cooling systems are more advantageous than solid desiccant systems and adsorption cooling systems due to their ease of management, ultimately recommending solar-based cooling systems.

#### A. Solar Powered Cooling and Heating

performed a case study on solar-powered cooling systems applicable to both contemporary and historical buildings, indicating that an annual energy requirement of 465,450 kWh is essential for cooling these edifices.

conducted a theoretical examination of the climatic conditions in Blenheim, New Zealand, suggesting a 35kW cooling system for the city, with a projected payback period ranging from 15 to 20 years.

executed a theoretical analysis, advocating for the implementation of evacuated tube collectors and parabolic solar collectors for cooling and air conditioning systems powered by solar energy in buildings.

carried out a simulation study that explored two scenarios:

(1) Variation in working saturation temperature and (2) Fixed working saturation temperature. In the second scenario, the performance parameters of refrigeration improved with increased solar intensity but diminished in the evening. Conversely, in the first scenario, performance metrics such as cooling capacity and power consumption decreased, indicating a higher sensitivity in this instance. Sarbu et al. [10] conducted a theoretical analysis, claiming that liquid desiccant systems

and absorption cooling systems are more advantageous than solid desiccant systems and adsorption cooling systems due to their ease of handling. They ultimately advocated for the implementation of solar-based cooling systems as a final recommendation.

performed a theoretical analysis on various working pairs, including the minimum and maximum operating temperatures, cooling capacity, and coefficient of performance (COP) for solar-powered cooling systems. Moria et al. [12] executed an experimental investigation on a solar-based, compressor-less refrigerator, employing a Peltier module for cooling. The cooling side of the module reached a temperature of 10.6°C, while the hot side attained 65°C. Ramadan et al. [13] conducted an experimental study on a solar-powered refrigeration system designed for the climatic conditions of Egypt, with the COP of the system varying from approximately 0.47 to 0.52.

#### B. Thermoelectric Cooling

The Peltier effect was initially identified by the scientist J.C.A. Peltier during the mid-18th century. This phenomenon demonstrates that when an electric current passes through two distinct materials, thermal energy is absorbed at one junction while it is released at the other, leading to cooling and heating on opposite sides of the materials. Figure 2(a) presents a systematic diagram of the Peltier effect. This effect is illustrated in the Peltier module shown in Figure 2(b), which is composed of N-type and P-type semiconductor materials.

carried out an experimental investigation using a Peltier module for cooling applications. The system's coefficient of performance (COP) was found to be 0.458, with a temperature decrease of 12°C recorded in the system utilizing the Peltier module.

performed a theoretical examination of cooling systems based on Peltier modules, emphasizing the various benefits of these modules as cooling devices. A review of the current literature reveals that extensive research has been conducted on solar-powered refrigeration systems; however, there is still a critical need for additional exploration in this field.

The author pointed out that no experimental studies have been documented regarding a Peltier module-based, compressor-free mini solar-powered refrigerator. To fill this void, a simulation study has been executed.

#### C. Setup Specification

The research employed a Peltier unit TIC 12073, which has a power rating of 20 watts. A heat sink with dimensions of 7.5 cm x 8 cm x 4.5 cm was utilized, along with two cooling fans that each consume 2.16 watts on the hotter side to effectively dissipate heat. Insulation was accomplished using Thermopolis and aluminum foil on both the outer and inner sides of the refrigerator to minimize thermal losses to the surrounding environment. A 160W solar panel from Exide was used to power the refrigerator, complemented by a 12V DC battery that acts as an additional cooling source and can be charged by the solar panel. Lastly, a 6 Amp ON-OFF switch was installed to manage the power supply from the solar panels to the refrigerator as required. The outer and inner dimensions of the system are presented in Table 1, while the circuit diagram of the refrigerator setup is depicted in Fig. 3.

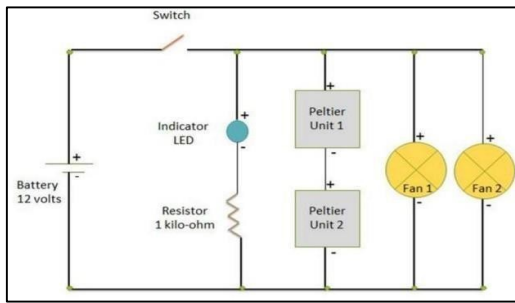

Fig.3 Circuit Diagram of the Experimental Study

Table 1 Dimensions of the Refrigerator

Outer length (cm)	30
Outer Width (cm)	20
Outer Height (cm)	21
Inner length (cm)	25.5
Inner Width (cm)	15.5
Inner Height (cm)	8
Volume (L)	3.162

### III. RESULTS AND DISCUSSIONS

Table 2 Data Obtained from Experiment

Reading	Sample	Starting Time	Duration	Max time	Max Temp	Average Temp	Min time	Min Temp	Result	End Time
1	30.9°C	26:02	00:12	26:02	30.9°C	30.5°C	26:1	29.7°C	Stable	26:15
2	29.6°C	26:15	00:07	26:15	29.6°C	28.9°C	26:2	28.4°C	Stable	26:22
3	28.3°C	26:22	00:08	26:22	28.3°C	27.8°C	26:3	27.2°C	Stable	26:31
4	27.1°C	26:31	00:18	26:32	27.1°C	26.5°C	26:4	26.1°C	Stable	26:49
5	26.0°C	26:49	04:39	29:23	26.6°C	26.1°C	31:2	25.0°C	Stable	31:29
6	24.9°C	31:29	00:08	31:29	24.9°C	24.4°C	31:3	24.0°C	Stable	31:38
7	23.9°C	31:38	00:17	31:38	23.9°C	23.5°C	31:5	23.0°C	Stable	31:55
8	22.9°C	31:55	00:45	31:55	22.9°C	22.4°C	32:3	22.0°C	Stable	32:41
9	21.9°C	32:41	01:02	32:43	22.1°C	21.7°C	33:4	21.0°C	Stable	33:43
10	20.9°C	33:43	00:17	33:43	20.9°C	20.4°C	33:5	20.0°C	Stable	34:01
11	19.9°C	33:01	00:28	34:01	19.9°C	19.4°C	34:2	19.0°C	Stable	34:29
12	18.9°C	33:29	01:29	34:34	19.0°C	18.3°C	35:3	17.9°C	Stable	35:58
13	17.8°C	35:58	03:30	39:27	18.8°C	17.6°C	38:4	17.2°C	Stable	39:29
14	17.4°C	39:29	00:06	39:35	19.8°C	19.3°C	39:2	18.9°C	Stable	39:36
15	17.4°C	39:36	00:17	39:40	20.4°C	19.7°C	39:5	19.9°C	Stable	39:53

- A temperature difference of 14°C was noted during an operational time of 22 minutes and 6 seconds.
- The lowest temperature recorded during the study was 16.9°C.

Table 2 displays the complete data gathered from the experiment; the refrigerator's starting temperature was noted at 30.9°C, which fell to 16.9°C over a period of 22 minutes and 6 seconds.

Furthermore, Fig. 4 depicts the entire temperature fluctuation in relation to time.

### IV. CONCLUSIONS

Upon completing the experimental study, several conclusions were drawn:

- The Peltier module is suitable for refrigeration applications; however, further improvements are required for its implementation in larger refrigerators.
- The refrigerator is capable of operating for 3.18 hours when utilizing two Peltier modules.
- The operational duration of the refrigerator can be prolonged by integrating a larger battery into the system.

### ACKNOWLEDGMENT

The authors thank the reviewer and editors for the improvement of the manuscript.

### REFERENCES

- [1] Negi, G. S. Dhindsa, and S. S. Sehgal, "Experimental investigation on single basin tilted wick solar still integrated with flat plate collector," *Mater. Today Proc.*, no. September, 2021, doi: 10.1016/j.matpr.2021.09.210.
- [2] P. Negi, R. Dobriyal, D. B. Singh, and G. K. Badhotiya, "Materials Today : Proceedings A review on passive and active solar still using phase change materials," *Mater. Today Proc.*, no. xxx, 2021, doi: 10.1016/j.matpr.2020.12.996.
- [3] Negi, G. S. Dhindsa, and S. S. Sehgal, "Performance Enhancement of Solar Still Using Heat Storage Medium and Nanoparticles," *Int. J. Adv. Sci. Technol.*, vol. 29, no. 10, pp. 5508–5513, 2020.