

Bio-Medical Intelligent Saline Bottle Monitoring System

Matha Swetha¹

¹Assistant Professor, Department of ECE, Sri Sivani College of Engineering, Chilakapalem, India

Abstract -

Hospital employees and health professionals are under a significant lot of stress and strain in pandemic scenarios. The purpose of this invention is to eliminate the requirement for the nurse to monitor the fluid level on a regular basis. This invention is a built-in alarm system that monitors the levels of saline or electrolyte bottles provided to patients. It uses a non-contact capacitive switch sensor to detect if the fluid level falls below a predetermined level. The sensor talks with the microprocessor, which then sends a text message and makes a phone call to a specified number to notify them. If someone is present in the room, a buzzer will be placed near the patient's bed to alert them. This saves time and prevents medical errors from occurring if the saline or electrolyte bottle isn't replaced or replenished on time. standard saline bottle. The ineffectiveness of IR sensors un this case is due to their low sensitivity. Sound waves are used by flow rate sensors to estimate the flow rate of fluid passing through a pipe. However, this sensor can be used because the flow rate is slow and precise because it is in the form of droplets. Ultrasonic level sensors use ultrasonic waves to determine the level of fluid in a bottle. The sensor sends out an ultrasonic pulse that is reflected back to it by the target. It is inserted in the bottom of a saline bottle, which is inconvenient because it necessitates bottle modification.

Key Words: GSM, Alert system, Saline Bottle, Heal

2. Working of the Invention

1. INTRODUCTION

When we realised that we needed to manually monitor fluid levels on a regular basis, we came up with this notion for innovation. However, due to the health care professional's hectic schedule, they may forget to change or refill the bottle at the appropriate time. As a result, patients' lives may be compromised because air bubbles or blood backflow may enter the bloodstream, both of which can lead to patient death. As a result, by eliminating the need to manually monitor fluid levels on a regular basis, this innovation will be tremendously valuable in enhancing the health-care system.

The fluid level of the bottle is measured using a load cell. It's a sort of transducer that converts its load-induced deflection into an electrical quantity. The electrical signal varies accordingly as the fluid level drops. When the patient moves their hand, the signals fluctuate. The value of its output is fleeting. As a result, we discarded this sensor.

Another option is to use an infrared sensor, which may be used as both a transmitter and a receiver. Some of the radiation emitted by the IR transmitter reaches the object and is reflected back to the IR receiver. The sensor's output is determined by the intensity of the IR receiver's reception. Both the IR transmitter and the IR receiver must be properly enclosed in order to eliminate reflections from items other than the target, which is not suitable with a

2.1 Detailed Description of the Invention

The following is a description of one of the present

invention's specific embodiments. Data acquisition, microcontroller, wireless communication system, and alarm system are the four key components of the present invention.

The non-contact liquid level sensor that is affixed to the outer surface of the medicinal fluid delivery bottle is used for data collecting. To perform non-contact fluid level sensing, the sensor employs modern signal processing technologies. The sensor is used to keep track of the amount of fluid in the bottle at all times. When the liquid level surpasses a specified threshold, the sensor produces a very accurate and stable signal. The system's analogue to digital converter receives the analogue signal of the fluid level sensed by the sensor and converts it to a digital 5 value, which is then passed on to the microcontroller. The digital signal indicating the fuel level in the bottle is received by the microcontroller. At the same time, the microcontroller compares the signal value to a threshold level. When the sensor's value goes below a pre-determined threshold, the Microcontroller sends two signals: one to the buzzer and the other to the GSM module.

The fluid or electrolyte that is scheduled to be given to the patient will be contained in the saline bottle. This saline container will have a liquid level sensor 2 added to it to

show the level and alert you if it drops below a particular threshold.

The saline container is coupled to a non-contact liquid level sensor 2 for continuous fluid level monitoring. It works by varying capacitance as a function of the water/liquid. In the absence of liquid near the sensor, distributed capacitance will exist, resulting in some static capacitance to ground on the sensor. As the amount of liquid near the sensor increases, the parasitic capacitance of the liquid is coupled to the static capacitance, increasing the sensor's final capacitance value. The changed capacitance signal is then input to the control IC for signal conversion, which converts the varied capacitance into the amount of change in the electrical signal. Finally, when the amount of change exceeds a specified threshold, which signifies the liquid level has reached the induction point, the 25 degree of variation can be computed using a certain algorithm. When the fluid level exceeds a defined point, a HIGH signal and a red light will continue to be generated.

Capacitance will vary and the red light will switch off if the liquid level falls below a predefined level. This sensor will be connected to ADC 3, which will receive an analogue signal based on capacitance fluctuation.

The non-contact liquid level sensor 2 is connected to ADC 3, which will receive an analogue signal based on capacitance fluctuation. This ADC 3 will convert the analogue signal to a digital signal, which will then be transferred to the Arduino Nano 4.

The Arduino Nano 4 is a small, comprehensive, and breadboard-friendly board with an ATmega328 microcontroller (Arduino Nano 3.x). It's an 8-bit controller that runs on 5V. The ADC 3 is attached to the Arduino Nano 4. It will receive digital signals from ADC 3; when liquid is available, it will continue to receive a HIGH signal, and when a LOW signal is received, Arduino Nano will send a signal to GSM module 8 to make a call or send a message. The buzzer 7 is also linked to the Arduino Nano 4, which receives the signal and buzzes to generate a warning.

Switch 5 is used to turn the system on and off, preventing the battery from being depleted ineffectively while it is not in use. The system is powered by a rechargeable battery number

six. The Arduino Nano 4 will be used to recharge it

and is a mobile communication modem (GSM). A GSM modem is a device that allows a computer or any other processor to interact via a network. It can be a phone or

modem. A GSM modem requires a SIM card and runs on a network range that has been subscribed to by the network operator.

Arduino Nano 4 is connected to GSM modem 8. It will receive a signal to send an alarm SMS to the program's specified number. It will also phone the supplied number for an alert.

There will be another device into which a sim card can be inserted, the number of which will be specified in the Arduino Nano 4 programme. So, if an alarm is required, an SMS and a phone call will be received on this device via the sim card.

The primary goal of the current invention is to notify medical personnel, such as nurses or doctors, as well as the patient's family, when the fluid supplying to the patient from the medical bottle is likely to run out. As a precaution, a buzzer is installed at the patient's bedside, which emits a buzz sound as soon as the sensor's value goes below the threshold value. This number will notify family members to notify the nurse about the fluid level conditions.

In the event that no one is present near the patient, the system includes a GSM module with a registered SIM card. The microcontroller's digital output is supplied to the GSM module, which sends a text message containing the room number and the patient's name. In the event that the medical professionals have not read the message, the GSM module will phone them.

2.2 Arduino R3 Code [3]

```
#include <SoftwareSerial.h>

SoftwareSerial mySerial(10,11);

char msg;
char call;
int MakeCallCount = 0;

int SendMessageCount = 0;
const int FluidSensor = 3;
const int buzzer = 6;

void setup() {

pinMode(FluidSensor,INPUT);
pinMode(buzzer, OUTPUT

Serial.begin(9600);
delay(100); }
```

```

void loop() {
  if
  (digitalRead(FluidSensor)=
  = LOW){

digitalWrite(buzzer, HIGH); }

else {
ofCTRL+ZdigitalWrite(buzzer, LOW);}
if(digitalRead(FluidSensor)
== LOW && MakeCallCount == 0
&& SendMessageCount == 0)
//Check the sensor output{ //Fluid_low_Count++;
Serial.println("HELP ME");

MakeCall();
SendMessage(); }

if(digitalRead(FluidSensor)== HIGH && MakeCallCount == 1
&& SendMessageCount == 1) //Check the sensor output{
//Fluid_high_Count++;
MakeCallCount = 0;
SendMessageCount = 0;
Serial.println("i'm safe"); }
delay(10);
if (mySerial.available()>0){
Serial.write(mySerial.read()); }}
void MakeCall(){
MakeCallCount++;
mySerial.println("ATD+xxxxxxxxxxxx"); //
ATDxxxxxxxxxxx; -- watch out here for semicolon at the end!!

delay(10000); }
void SendMessage(){

mySerial.println("AT+CMGF=1"); //Sets the GSM Module in
Text Mode

delay(1000); // Delay of 1000 milli seconds or 1 second
    
```

Pin 30 of the Arduino NANO 4 is connected to the positive terminal of a 9V rechargeable battery 6 via switch 5 with red

```

mySerial.println("AT+CMGS=\"+xxxxxxxxxxxx\"r"); //
Replace x with mobile number

delay(1000);

mySerial.println ("yyyyyyyyyyyyyyyyyyyyyyyyyyyyyyyyyyyy!!!!!!");//
Replace y with The SMS text you want to send

delay(100);

mySerial.println((char)26);// ASCII code
SendMessageCount++;
delay(1000); }
    
```

3. Description of Drawings:

The block diagram of the present invention is shown in Figure 1.

The innovation can be divided into two subsystems: one that includes all of the sensors, and another that includes the microcontroller.

A saline bottle 1, a non-contact liquid level sensor 2, a switch 5, a battery 6, a buzzer 7, and a receiver 9 make up the sensory subsystem.

Invention also includes an Arduino Nano 4, an ADC 3, and a GSM module 8, all of which are connected to the Arduino Nano.

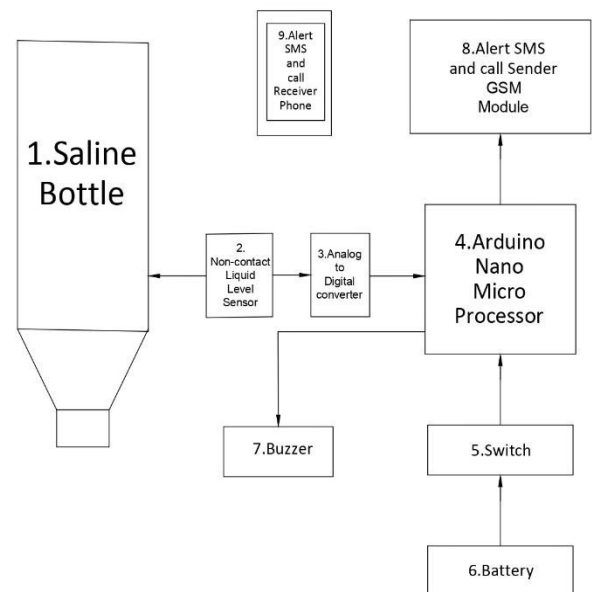

Figure 1

The circuit connections of the present invention are shown in Figure 1.

wire, and pin 29 of the Arduino NANO 4 is connected to the negative terminal of the battery via black wire. The GSM module 800L 8, VCC pin 2, and A to D converter 3, VCC pin 2 are likewise linked to the Arduino NANO 4, pin 30 with red wire. GSM module 800L 8, pin 6, analogue to digital converter

3, digital pin 3 and buzzer 7, negative terminal with black wire are all linked to pin 29 of Arduino NANO 4.

Green wire connects the Arduino NANO 4, pin 1, TX1 to the GSM module 800L 8, pin 4, RXD. Pin 2 of the Arduino NANO 4 is connected to the GSM module 800L 8, pin 5 of the TXD with blue wire, and pin 2 of the Arduino NANO 4 is connected to the GSM module 800L 8, pin 5 of the TXD with blue wire.

With purple wire, Arduino NANO 4, pin 9, D6 is linked to the buzzer 7, positive terminal. The analogue to digital 15 converters digital 3, pin 1, OUT is linked to the Arduino NANO 4, pin 6, D3 using blue wire.

The non-contact liquid level sensor 2, pin 1(Brown), VCC is linked to the analogue to digital converter 3, analogue pin 1, VCC via red wire. The non-contact liquid level sensor 2, pin 2(Yellow), is linked to the analogue to digital converter 3, analogue pin 2, OUT using green wire. The non-contact liquid level sensor 3, pin 3(Blue), GND with black wire is linked to analogue pin 3 of the analogue to digital converter 3. The analogue to digital converter 3, analogue pin 4, ADJ is linked to the non-contact liquid level sensor 2, pin 4(black), ADJ with purple wire.

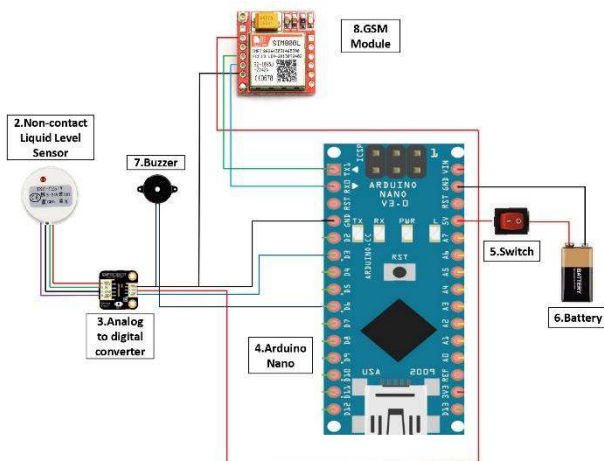

Figure 2

The isometric exemplary diagram of the present invention

is shown in Figure 3.

The typical diagram of the sensor retrofitted to the bottle demonstrates how it will be done clearly. A resizable

elastic band 10 will be used to bind the sensor 2 to its mount 11 and to the saline bottle 1. The sensor 2 will not be overly tight or loose around the saline bottle 1 if this fitting is used. The mount 11 is comprised of a flexible plastic material. This arrangement is intended to be simple and reliable.

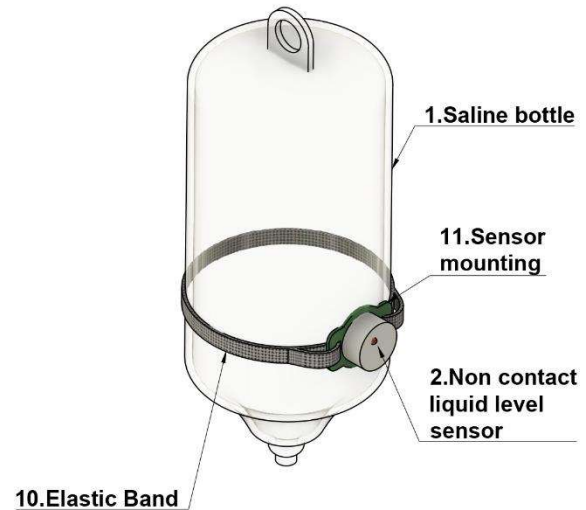

Figure 3

4. CONCLUSION

Medical workers will benefit greatly from this technology, which will aid in the prevention of medical errors in hospitals. It's a low-cost product with a high-quality component, thus it's cost-effective in terms of money. This reduces nonproductive work and prevents medical mishaps that can occur if a saline or electrolyte bottle isn't refilled or replenished on time.

REFERENCES

- [1] Introduction to Lithium Polymer Battery Technology Introduction to Lithium Polymer Battery Technology-2. (n.d.). www.jauch.com,
- [2] Arduino, "Arduino - Reference," Lang. Ref., p. 1, 2016,[Online].Available:<https://www.arduino.cc/en/Reference/HomePage>.
- [3] S.Gupta, M.Kulkarni, and Y.Kulkarni, Smart Saline Monitoring System Using Load Cell and RF Sensor, International Research Journal of Engineering and Technology (IRJET), 05 (06),2018.
- [4] D.Baviskar, P.Patil, S.Bhatambre, M.Hake, and S.Adsure, IoT BASED SALINE LEVEL MONITORING SYSTEM, Open access international journal of science,10.1088/1757-899X/981/3/032095

[5] A.Phaniraj, Gayatri K, J.Thomas, and Dr S Prabhanja,
Management of Saline and Electricity using IOT,
Journal of Computer Science Engineering and